

CONFIDENTIAL

THIS DOCUMENT AND INFORMATION CONTAINED HEREIN IS PROPRIETARY AND CONFIDENTIAL TO PRECOR STRENGTH INCORPORATED. RECIPIENTS OF THIS DOCUMENT AGREE THAT THIS DOCUMENT AND INFORMATION WILL NOT BE USED FOR ANY PURPOSE, REPRODUCED OR COPIED, OR DISCLOSED TO ANY THIRD PARTY, EITHER IN WHOLE OR IN PART WITHOUT PRIOR EXPRESS WRITTEN PERMISSION OF PRECOR STRENGTH, INCORPORATED.

PRECOR USA
PRECOR STRENGTH, INC.

28936 AVE WILLIAMS
VALENCIA, CA 91355
TELEPHONE: 661-362-0300

SIGN IN BLUE OR BLACK INK ONLY		
DRWN BY	01.02.07	MGP
DWG CHK		
ENG	01.02.07	RSG
MPG ENG		
CS		
QA		
ID		
REG		

UNLESS OTHERWISE SPECIFIED:
DIMENSIONS ARE IN INCHES
TOLERANCES ARE:
LIN .X=±0.1 .XXX=±0.010
LIN .XX=±0.02 .XXXX=±0.0001
ANGULAR: ±1.0°
ALL DIMS AFTER PLATING
BREAK ALL SHARP EDGES
REMOVE ALL BURRS
ALL ANGLES & BENDS 90°
DWG PER ASME Y14.5M-1994
DO NOT SCALE DRAWING
ALL MACHINED SURFACES

PRODUCT:
STRENGTH

ASSEMBLY CONNECTION, 10.5, W/ 1 PULLEY HSG

DWG. NO.	CW31868-402	SUBREV	A
----------	-------------	--------	---

SIZE	C	PAGE	1	OF	1
------	---	------	---	----	---

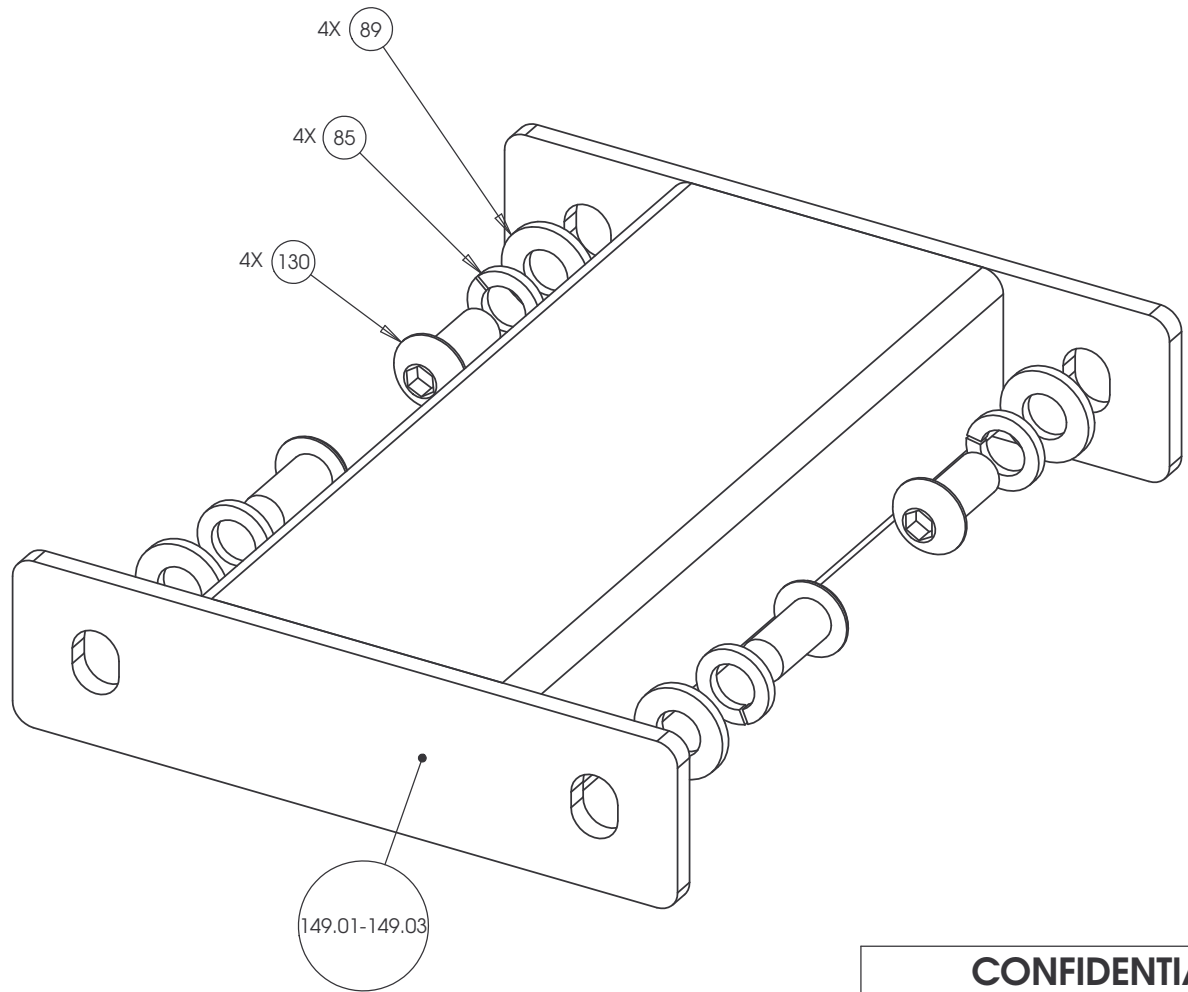

CONFIDENTIAL

THIS DOCUMENT AND INFORMATION CONTAINED HEREIN IS PROPRIETARY AND CONFIDENTIAL TO PRECOR STRENGTH INCORPORATED. RECIPIENTS OF THIS DOCUMENT AGREE THAT THIS DOCUMENT AND INFORMATION WILL NOT BE USED FOR ANY PURPOSE, REPRODUCED OR COPIED, OR DISCLOSED TO ANY THIRD PARTY, EITHER IN WHOLE OR IN PART WITHOUT PRIOR EXPRESS WRITTEN PERMISSION OF PRECOR STRENGTH, INCORPORATED.

PRECOR USA
PRECOR STRENGTH, INC.

28936 AVE WILLIAMS
VALENCIA, CA 91355
TELEPHONE: 661-362-0300

SIGN IN BLUE OR BLACK INK ONLY			UNLESS OTHERWISE SPECIFIED: DIMENSIONS ARE IN INCHES		PRODUCT: STRENGTH
DRWN BY	08.15.06	VLE	TOLERANCES ARE: LIN .X=±0.1 .XXX=±0.010 LIN .XX=±0.02 .XXXX=±0.0001		
DWG CHK			ANGULAR: ±1.0°		ASSEMBLY CONNECTION, 10.5
ENG	06.19.06	RSG	ALL DIMS AFTER PLATING BREAK ALL SHARP EDGES REMOVE ALL BURRS		
MFG ENG			ALL ANGLES & BENDS 90°*		
CS			DWG PER ASME Y14.5M-1994		
QA			DO NOT SCALE DRAWING		
ID			ALL MACHINED SURFACES		
REG			SIZE	PAGE OF	
			C	1 1	CW31874-402 A

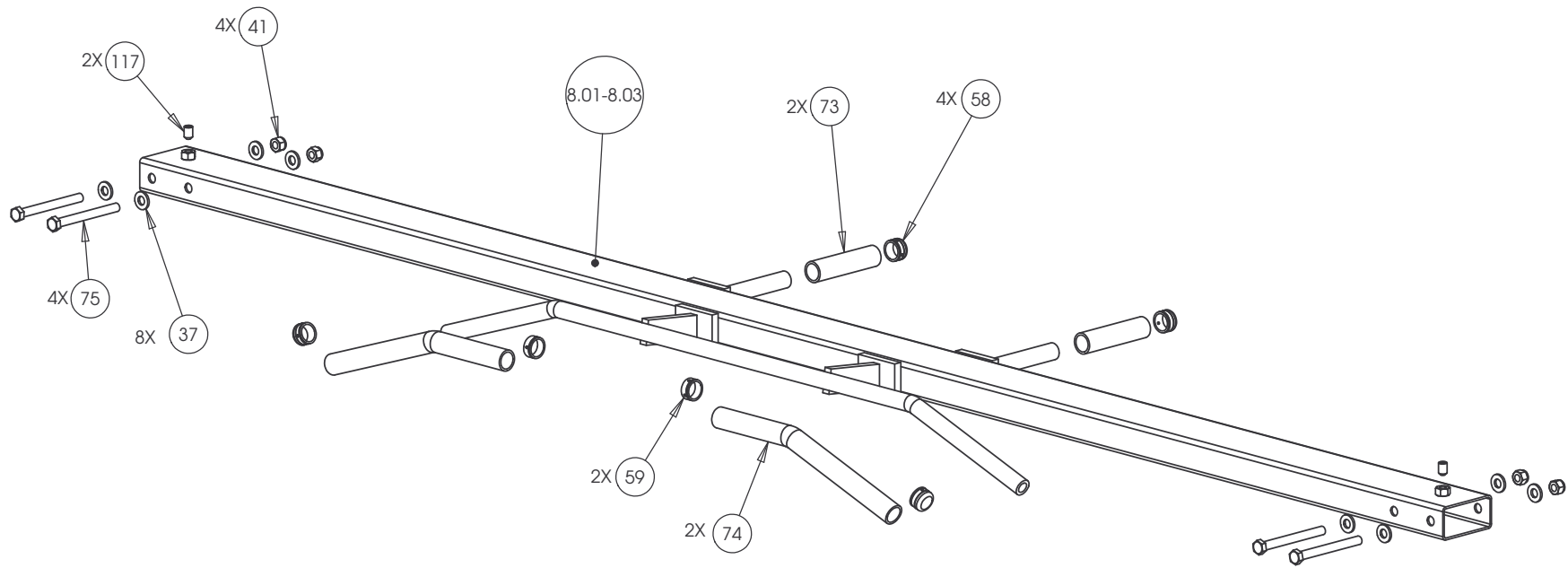

CONFIDENTIAL

THIS DOCUMENT AND INFORMATION CONTAINED HEREIN IS PROPRIETARY AND CONFIDENTIAL TO PRECOR STRENGTH INCORPORATED. RECIPIENTS OF THIS DOCUMENT AGREE THAT THIS DOCUMENT AND INFORMATION WILL NOT BE USED FOR ANY PURPOSE, REPRODUCED OR COPIED, OR DISCLOSED TO ANY THIRD PARTY, EITHER IN WHOLE OR IN PART WITHOUT PRIOR EXPRESS WRITTEN PERMISSION OF PRECOR STRENGTH, INCORPORATED.

PRECOR USA
PRECOR STRENGTH, INC.

28936 AVE WILLIAMS
VALENCIA, CA 91355
TELEPHONE: 661-362-0300

SIGN IN BLUE OR BLACK INK ONLY			UNLESS OTHERWISE SPECIFIED: DIMENSIONS ARE IN INCHES TOLERANCES ARE: LIN .X=±0.1 .XXX=±0.010 LIN .XX=±0.02 .XXXX=±0.0001 ANGULAR: ±1.0° ALL DIMS AFTER PLATING BREAK ALL SHARP EDGES REMOVE ALL BURRS ALL ANGLES & BENDS 90° DWG PER ASME Y14.5M-1994 DO NOT SCALE DRAWING ALL MACHINED SURFACES			PRODUCT: STRENGTH		
DRWN BY	01.02.07	MGP	SIZE	PAGE	OF	ASSEMBLY CONNECTION, 107 IN, CROSSBEAM W-HANDLES		
DWG CHK			C	1	1	DWG. NO. CW31878-401		
ENG	01.02.07	RSG				SUBREV A		
MPG ENG								
CS								
QA								
ID								
REG								

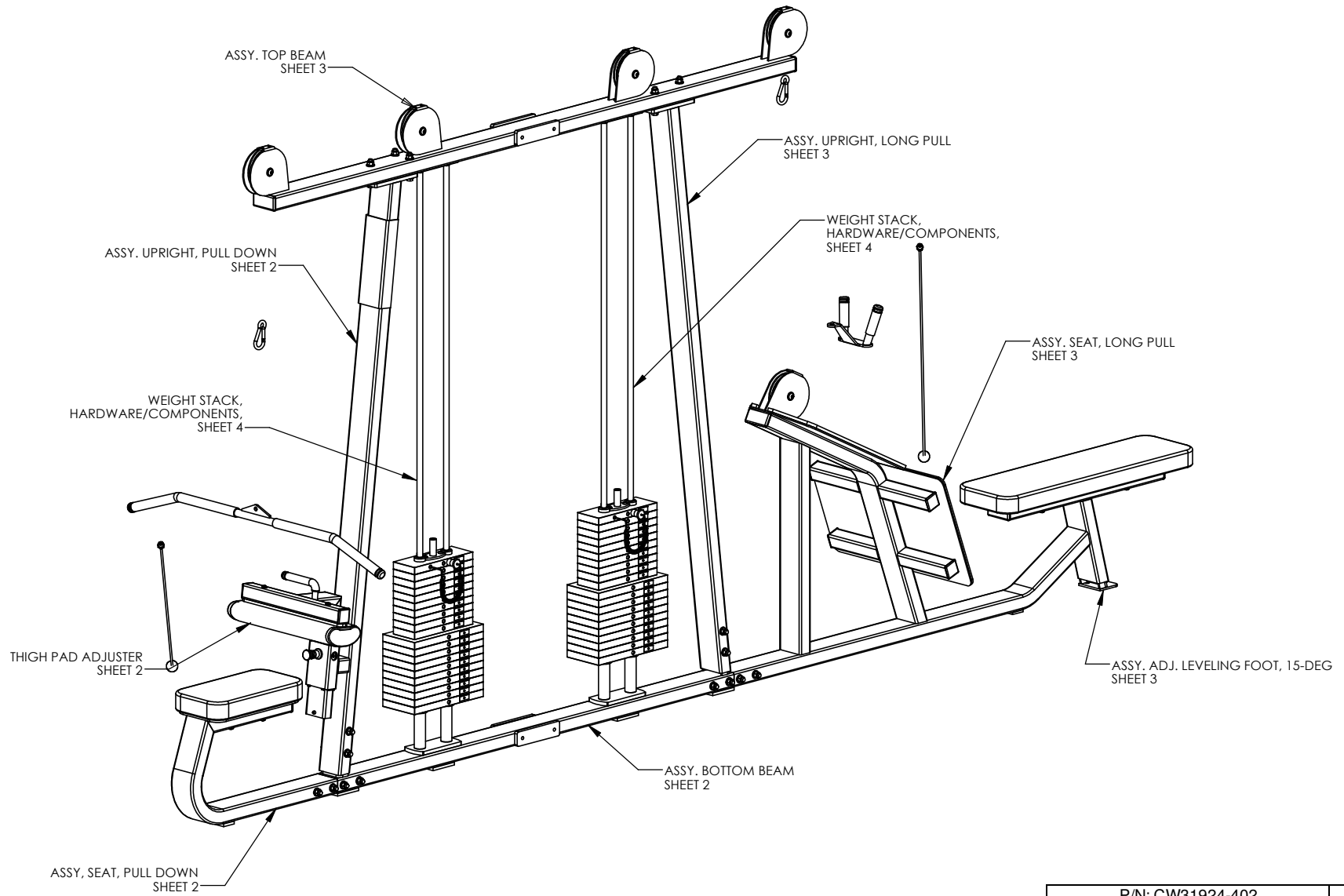

P/N: CW31924-402	SUBREV: C
DRAWN BY: JEC	DATE: 09.11.08
SHEET 1 OF 4	

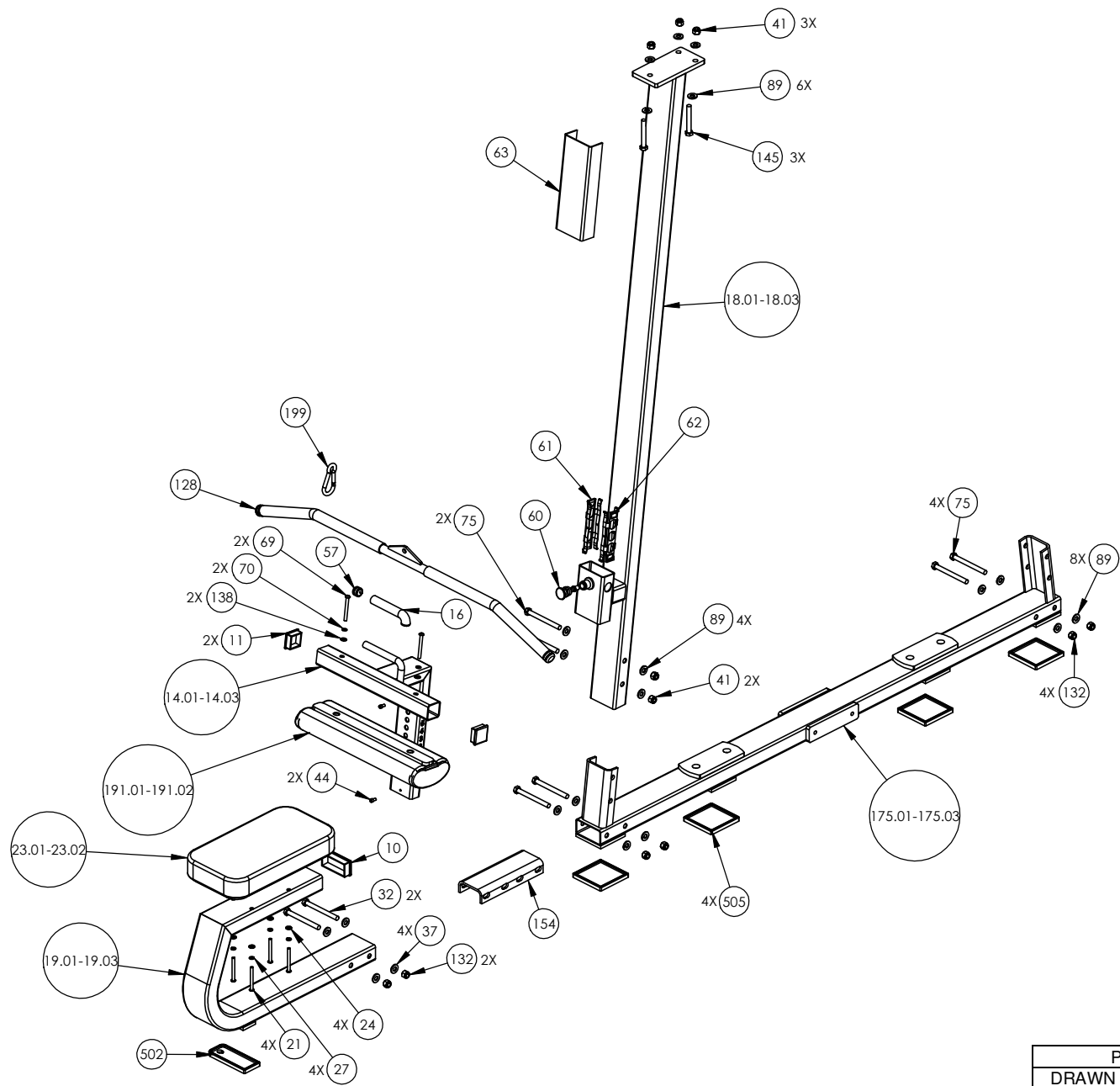

P/N: CW31924-402	SUBREV: C
DRAWN BY: JEC	DATE: 09.11.08 SHEET 2 OF 4

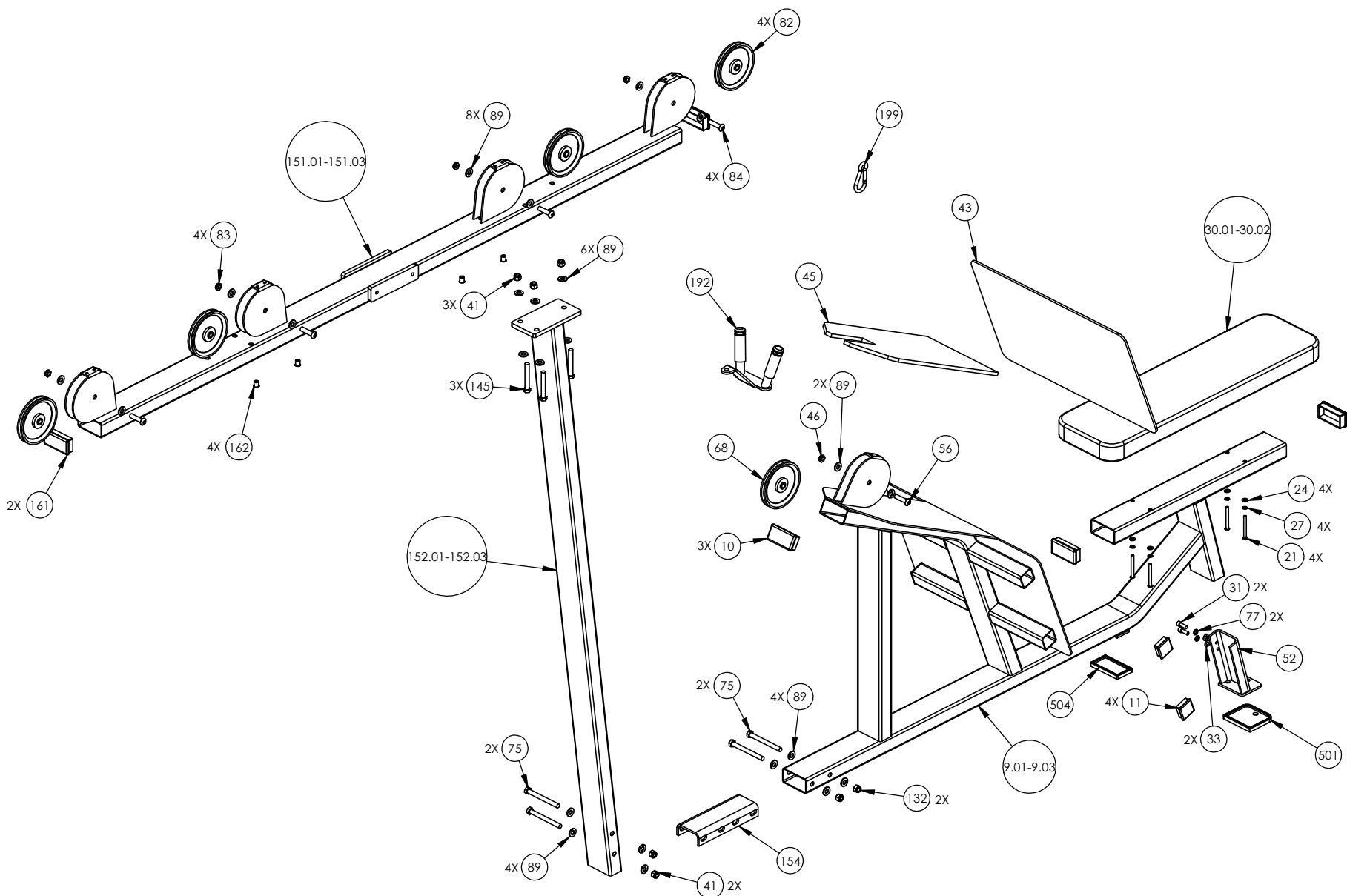

P/N: CW31924-402	SUBREV: C
DRAWN BY: JEC	DATE: 09.11.08
SHEET 3 OF 4	

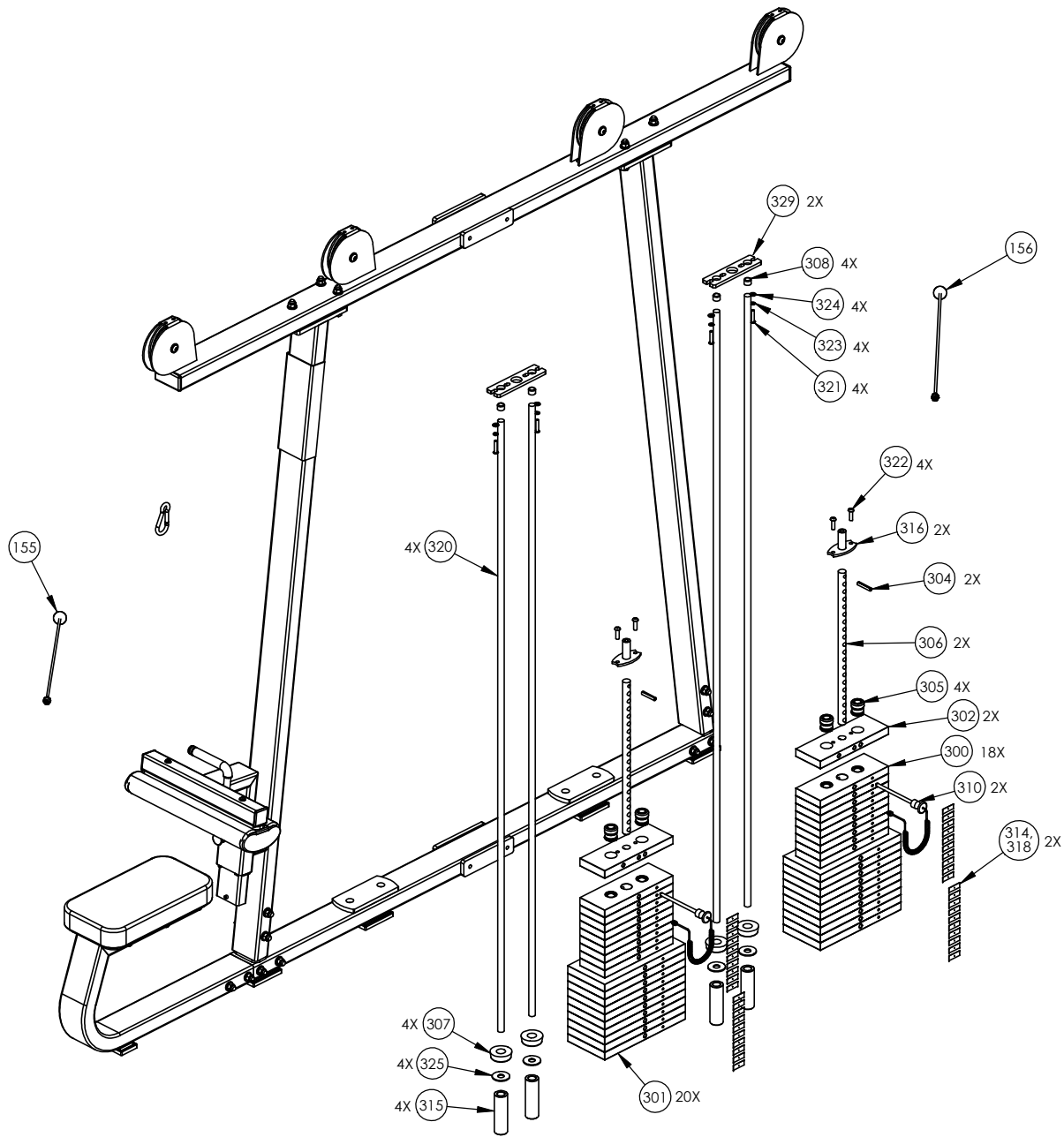

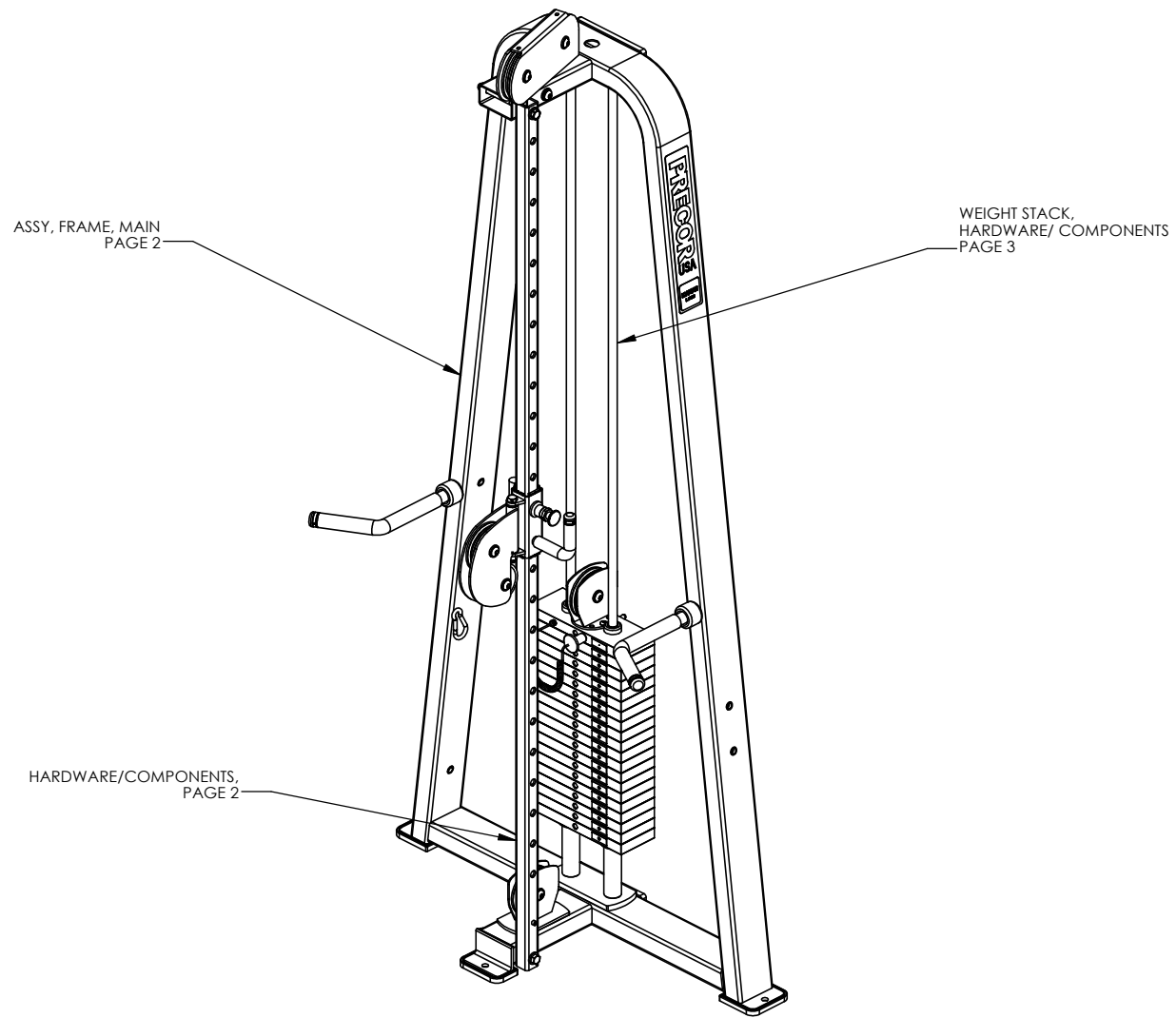

ASSY, FRAME, MAIN
PAGE 2

WEIGHT STACK,
HARDWARE/ COMPONENTS
PAGE 3

HARDWARE/COMPONENTS,
PAGE 2

P/N: CW34920-401		SUBREV: A
DRAWN BY: VLE	DATE: 06.24.09	SHEET 1 OF 3

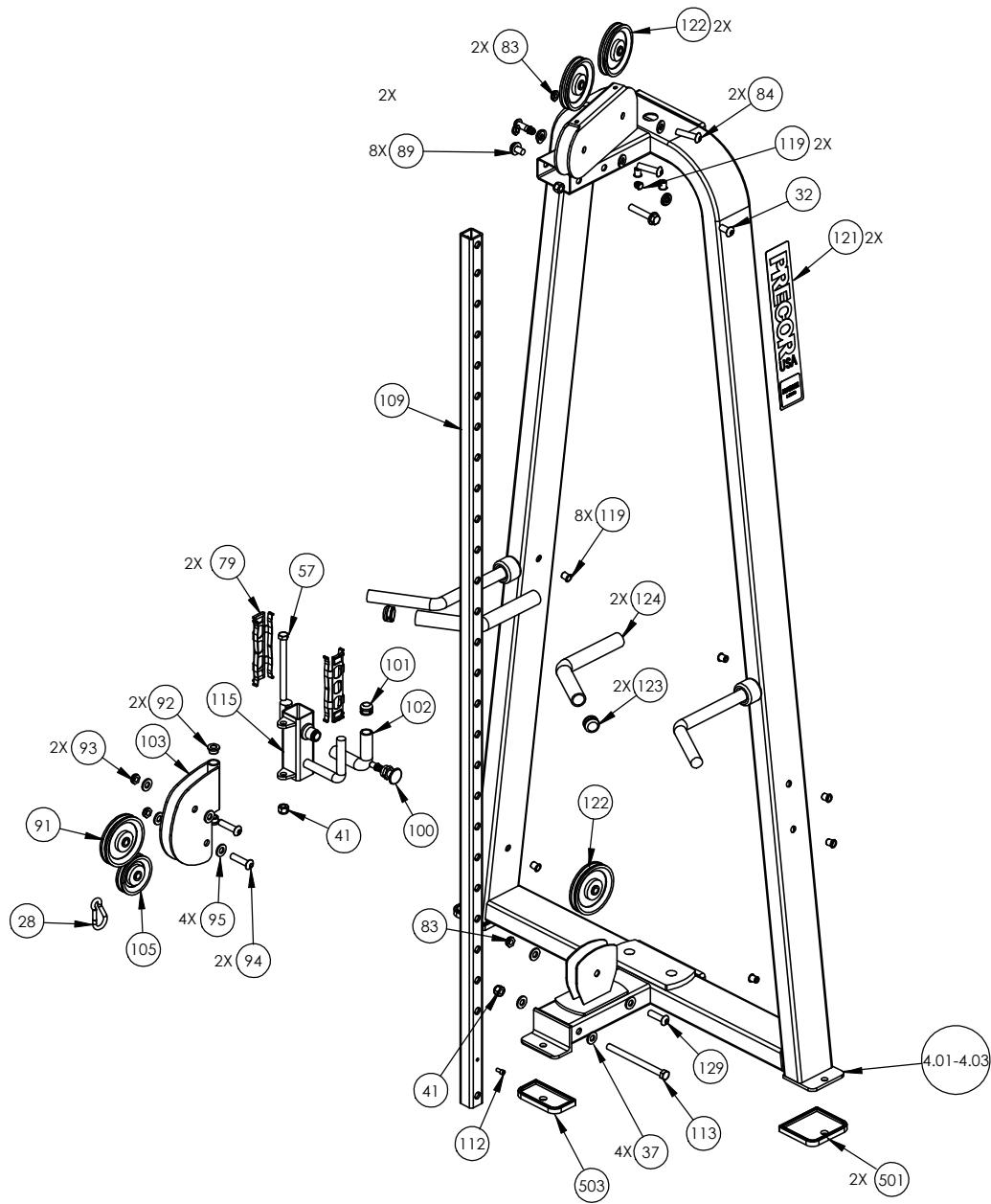

P/N: CW34920-401	SUBREV: A
DRAWN BY: VLE	DATE: 06.24.09
SHEET 2 OF 3	

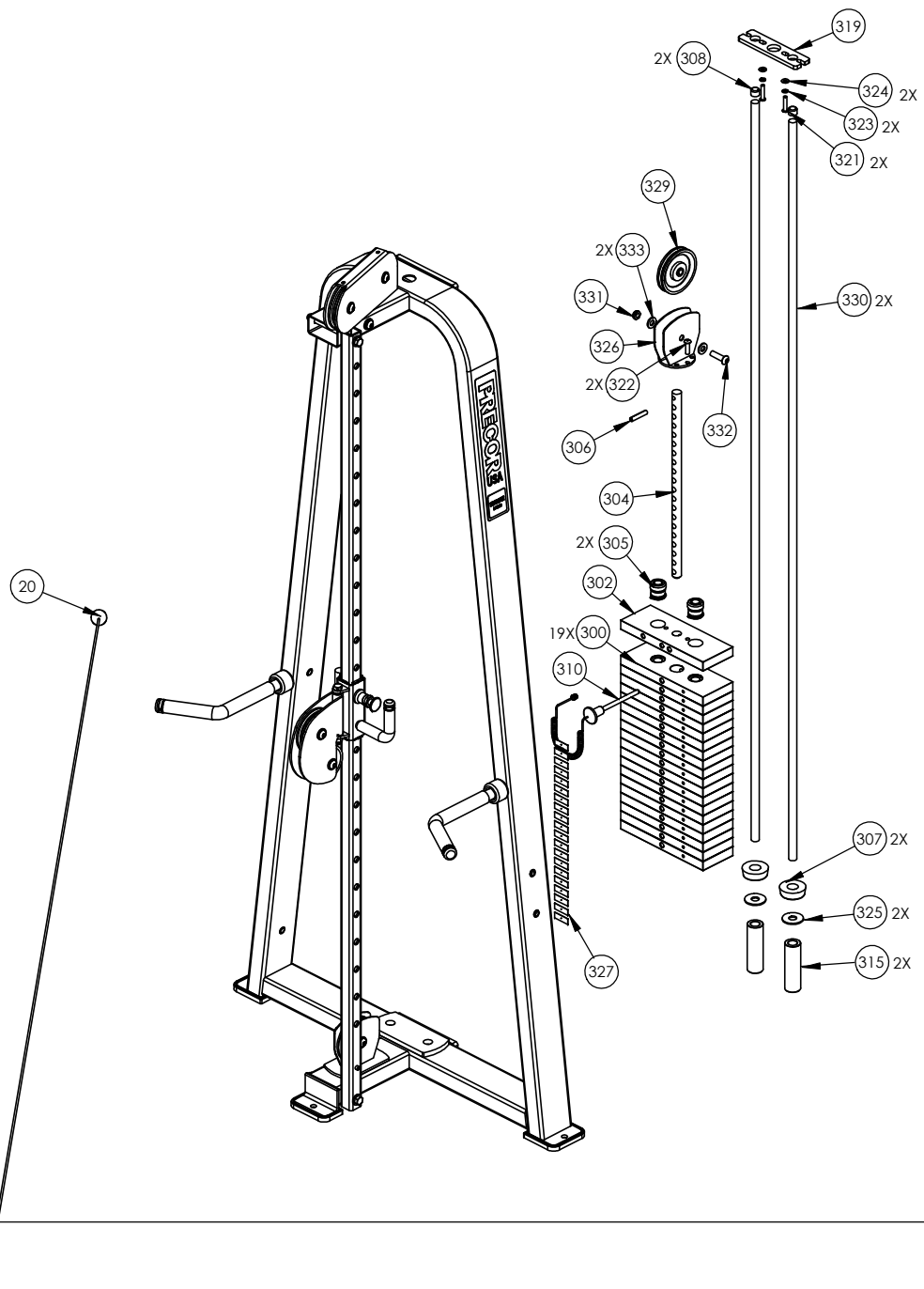

P/N: CW34920-401	SUBREV: A
DRAWN BY: VLE	DATE: 06.24.09
SHEET 3 OF 3	

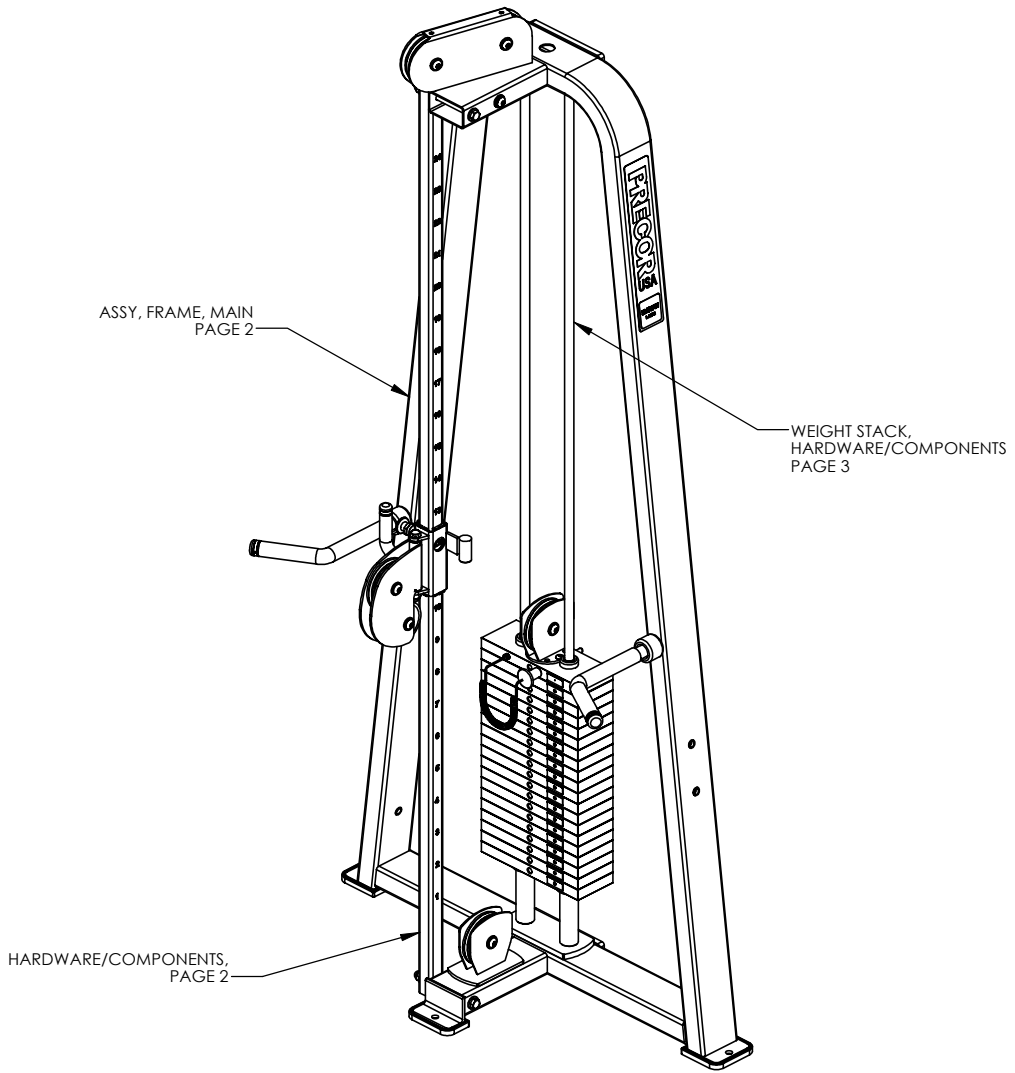

P/N: CW34921-401	SUBREV: A
DRAWN BY: VLE	DATE: 06.24.09
SHEET 1 OF 3	

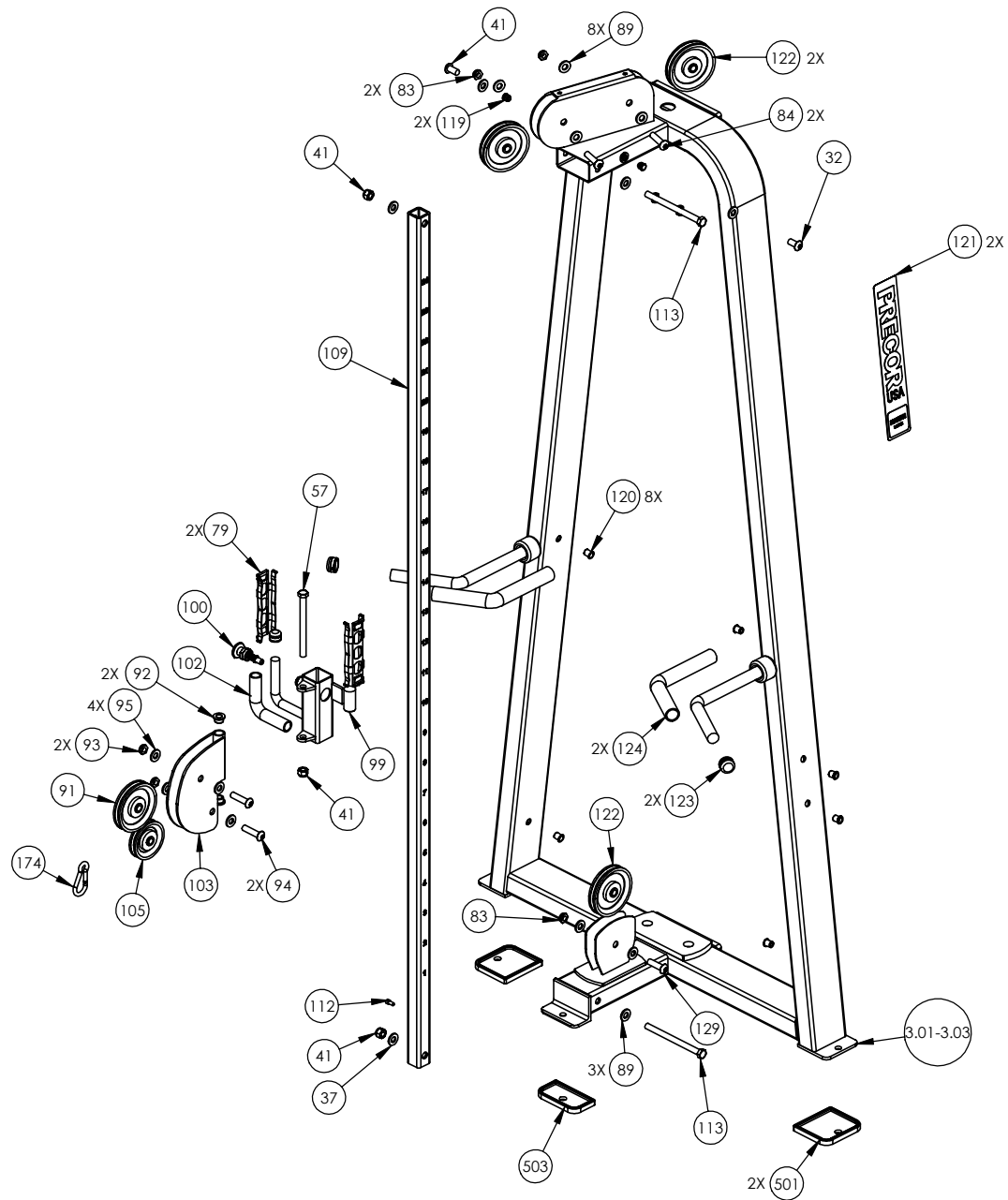

P/N: CW34921-401	SUBREV: A
DRAWN BY: VLE	DATE: 06.24.09
SHEET 2 OF 3	

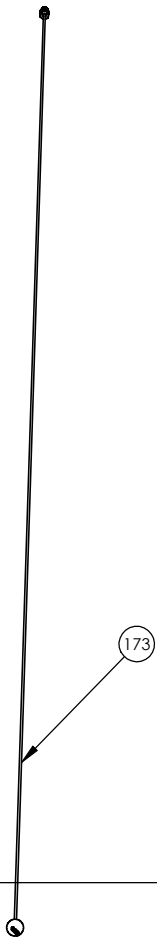
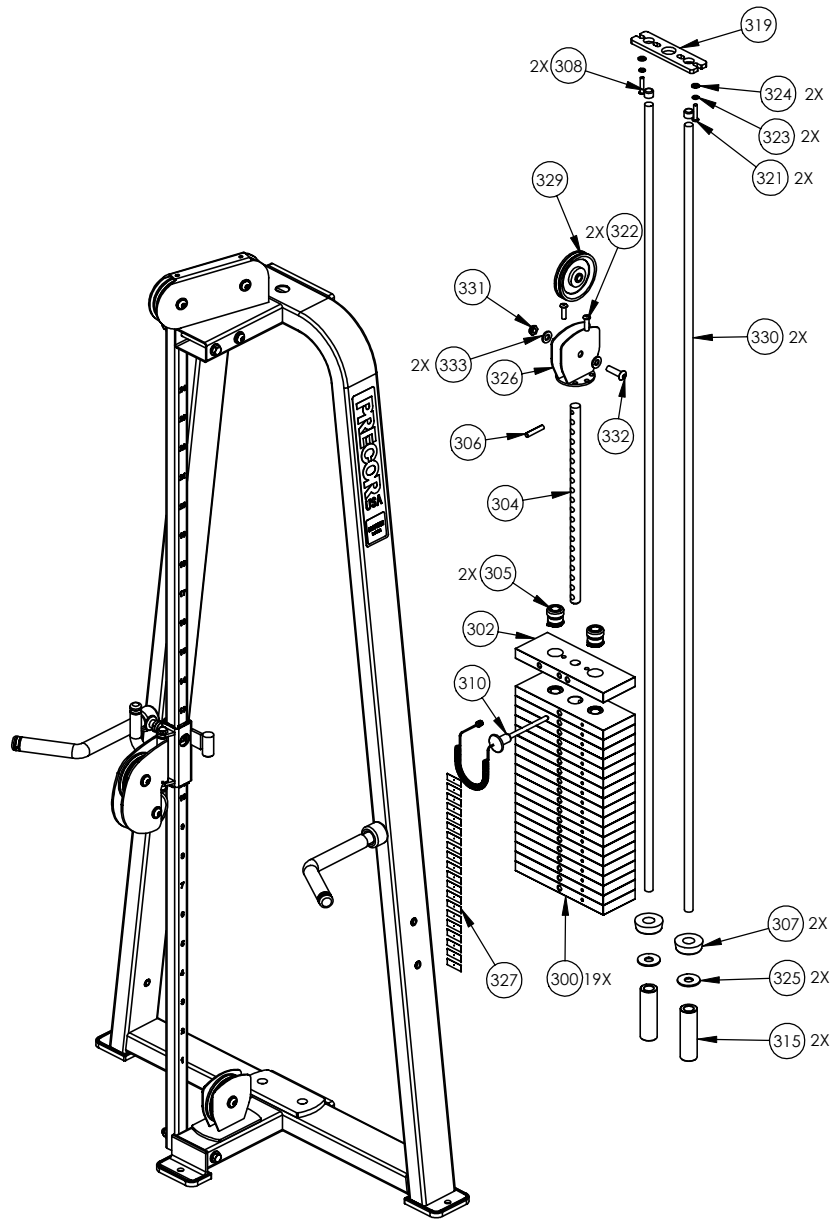

P/N: CW34921-401	SUBREV: A
DRAWN BY: VLE	DATE: 06.24.09
SHEET 3 OF 3	

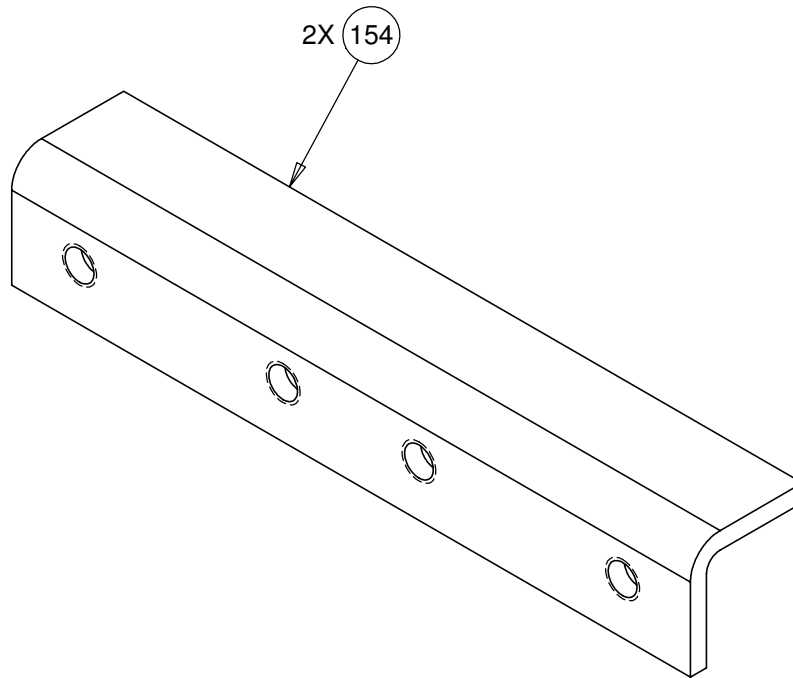

CONFIDENTIAL

THIS DOCUMENT AND INFORMATION CONTAINED HEREIN IS PROPRIETARY AND CONFIDENTIAL TO PRECOR STRENGTH INCORPORATED. RECIPIENTS OF THIS DOCUMENT AGREE THAT THIS DOCUMENT AND INFORMATION WILL NOT BE USED FOR ANY PURPOSE, REPRODUCED OR COPIED, OR DISCLOSED TO ANY THIRD PARTY, EITHER IN WHOLE OR IN PART WITHOUT PRIOR EXPRESS WRITTEN PERMISSION OF PRECOR STRENGTH INCORPORATED.

PRECOR USA
PRECOR STRENGTH, INC.

**28936 AVE WILLIAMS
VALENCIA, CA 91355
TELEPHONE: 661-362-0300**

SIGN IN BLUE OR BLACK INK ONLY			UNLESS OTHERWISE SPECIFIED: DIMENSIONS ARE IN INCHES TOLERANCES ARE: LIN .X=±0.1 .XXX=±0.010 LIN .XX=±0.02 .XXXX=±0.0001 ANGULAR: ±1.0° ALL DIMS AFTER PLATING BREAK ALL SHARP EDGES REMOVE ALL BURRS ALL ANGLES & BENDS 90° DWG PER ASME Y14.5M-1994 DO NOT SCALE DRAWING ¹²⁵ ALL MACHINED SURFACES		
DRWN BY	08.27.09	VLE			
DWG CHK					
ENG	08.27.09	VLE			
MFG ENG					
CS					
QA					
ID			SIZE	PAGE	OF
REG			A	1	1

PRODUCT:
STRENGTH

STEEL, CHANNEL

DWG. NO. CW33293-402 SUBREV A

HANDLES/COMPONENTS
SHEET 3

CARRIAGE/SLIDES,
SHEET 3

WEIGHTS/GUIDE RODS,
SHEET 4

FRAME/C-FRAME,
SHEET 2

CW320KS	P/N: CW33596-101	SUBREV: C
DRAWN BY: JEC	DATE: 09.11.08	SHEET 1 OF 4

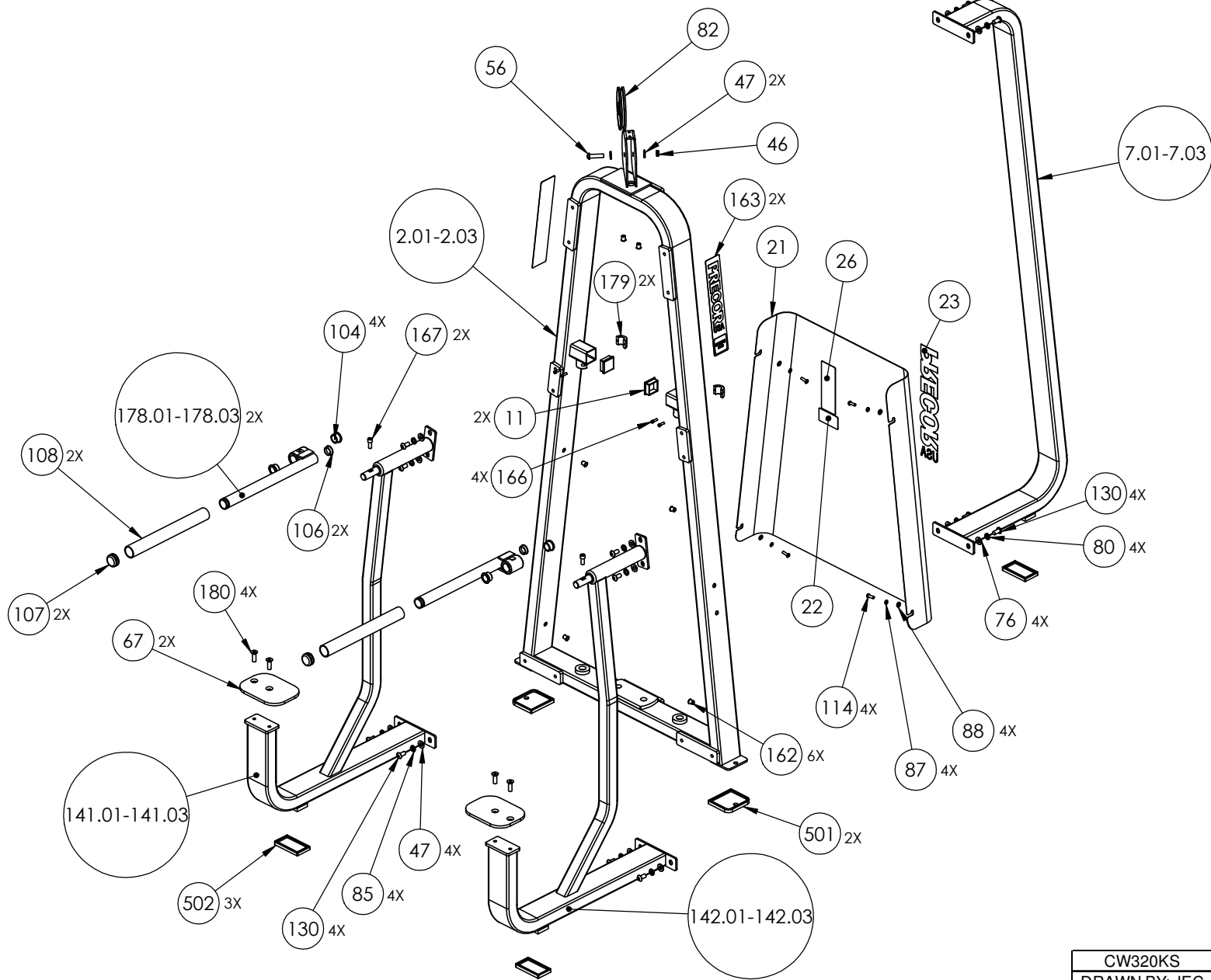

CW320KS	P/N: CW33596-101	SUBREV: C
DRAWN BY: JEC	DATE: 09.11.08	SHEET 2 OF 4

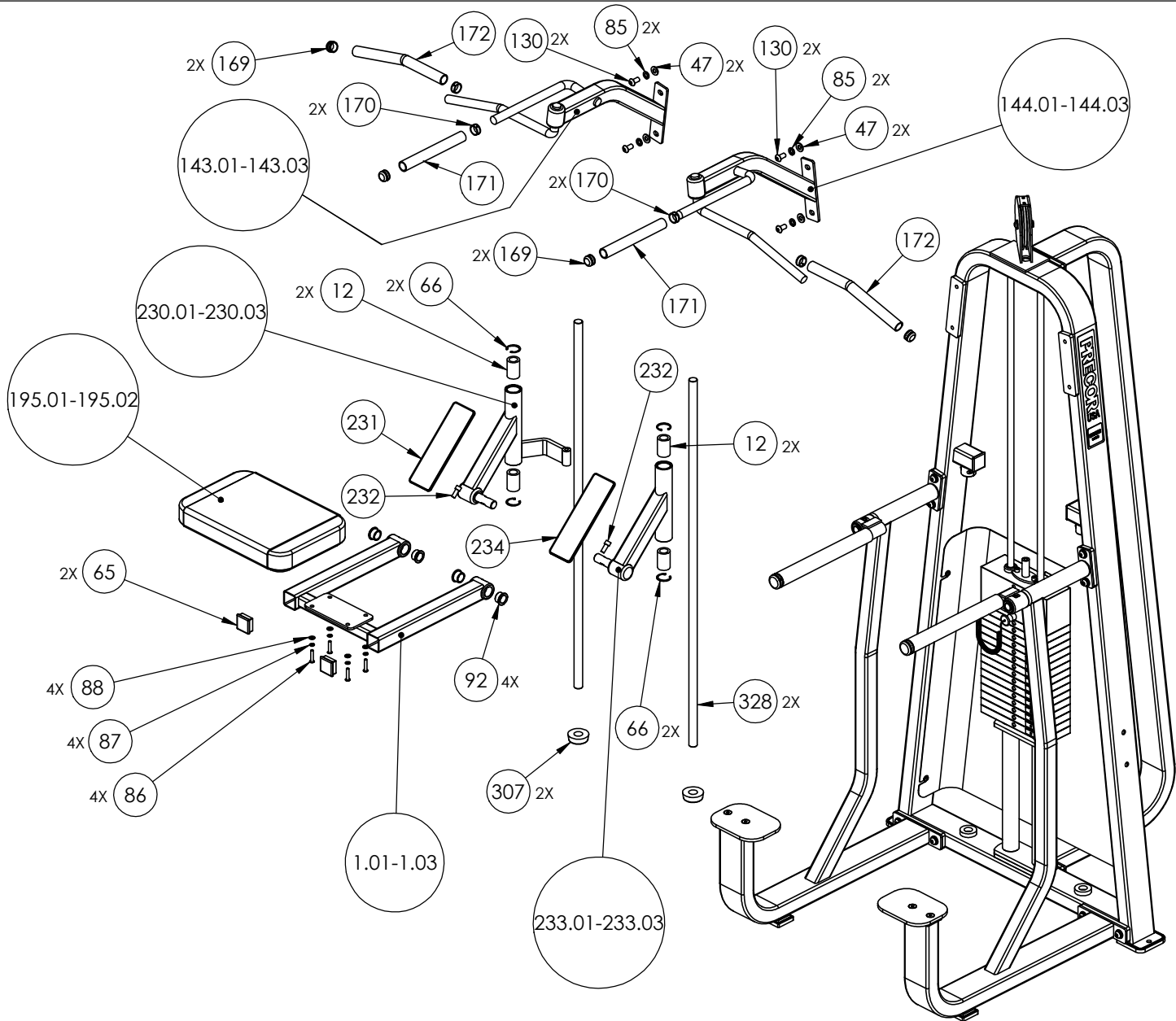

CW320KS	P/N: CW33596-101	SUBREV: C
DRAWN BY: JEC	DATE: 09.11.08	SHEET 3 OF 4

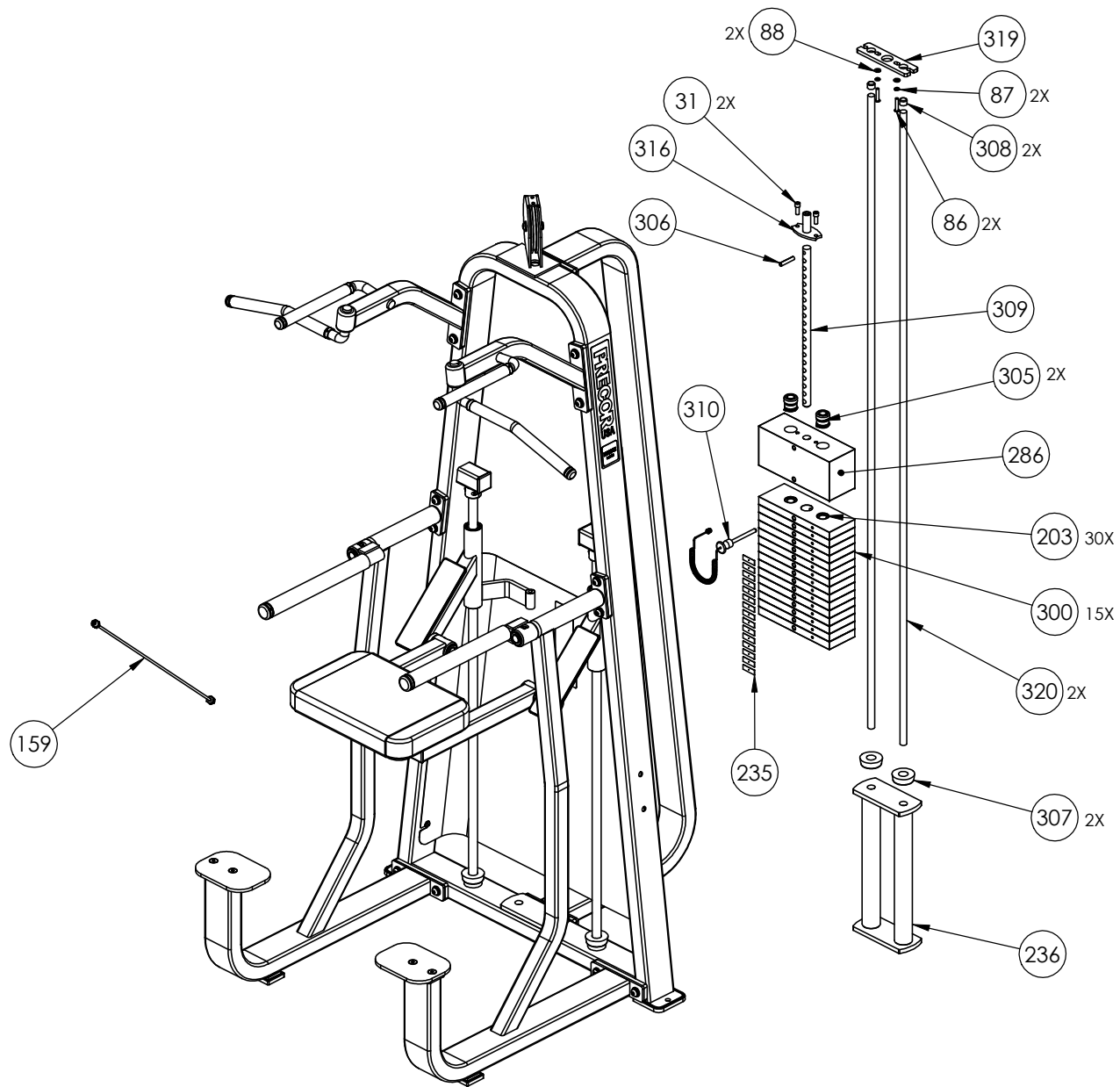

CW320KS	P/N: CW33596-101	SUBREV: C
DRAWN BY: JEC	DATE: 09.11.08	SHEET 4 OF 4